

Incorporating Main West Models
 Manufacturers, Wholesalers and Retailers of Quality Australian Model Railways
 PO Box 252 Warwick, Queensland, 4370 Australia
 Phone/Fax: 617 4667 1351 Website: www.arkits.com Email: info@arkits.com

RF04S-FD - UME GP Flat Wagon with Fordson Tractor Load

Prototype Data

The article in the August 1994 AMRM gives a concise history of the MLE flat wagons. In brief the MLE came into being as a result of war requirements between October and December 1944. A further batch of MLE wagons were constructed between February and October 1943 and numbered from 24350 to 24449 inclusive. During the post war era further MLEs were constructed between September 1947 and February 1948 numbered 25650 to 25674. The final batch of MLEs was part of an order for 250 vehicles placed with Goninan & Co, Broadmeadow. 72 of those vehicles were delivered as MLEs numbered 26275 - 26346 inclusive with the 178 remaining wagons constructed as UME un-bolstered wagons numbered 26347 - 26524. Other modifications to these wagons have occurred during their service life which has recently been covered in the model railway press.

Contents & Assembly Instructions

1 x floor, 2 x sides, 2 x ends, 2 x screws, 2 x bogies, 4 x wheel sets, decals and 1 brake detailing sprue, 1 x length brass wire and .1 pr Kadee #5 couplers, 16 x wheel chocks, 1 x length of chain.

- Using your modeller's tools carefully remove the parts from the sprue and clean up all the flash and ejector pin sprues..
- All floors have been checked and corrected to be flat. Please recheck the floor for bowing. Depending on the direction of the bow if any occurs it can be corrected. Place your thumbs on the points of the fish belly under frame or the floor opposite the points of the bow and pull ends of the wagon away from the bow with the inside flats of your fingers. Re-check for a flat floor/body moulding.
- Remove the draw angle from the top edge of the side sills and test fit to the floor. See **Diagram 1** for more specific detail. They may be slightly too long. If so remove equal amounts from both ends until they are both equal to the length of the floor. Using a reinforced backed razor blade carefully remove the brake slide from the side sill and transfer it to the other side and glue in position. See **Diagram 2**.

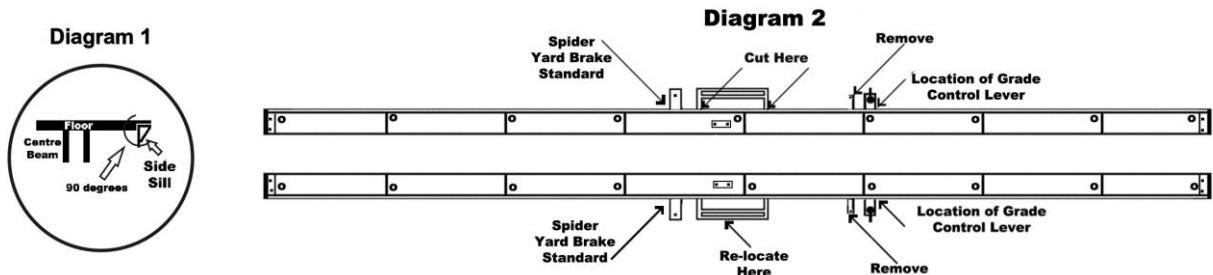

- Modify the brake cylinder as described in the attached **Diagram 3**. Cement to the piece of plastic stock supplied, locate and glue in position. Using the air tank indicated glue to the other piece of plastic supplied, locate and glue in position. **Diagram 4** gives a comprehensive layout of the underbody looking from the bottom.

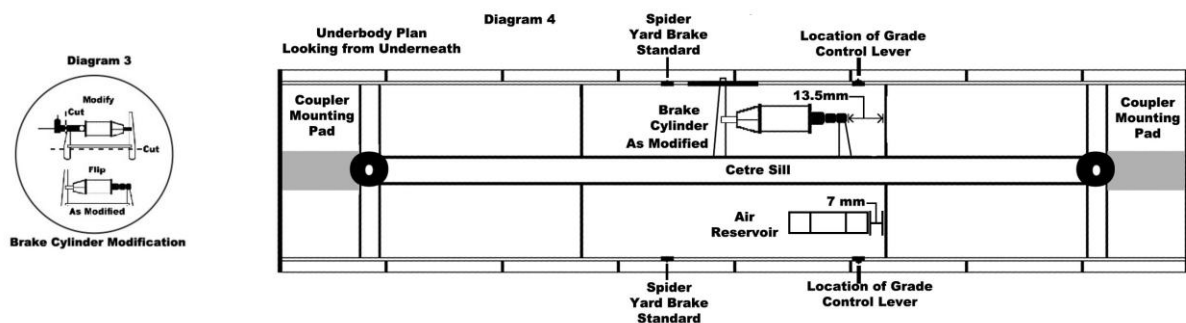

5. Drill a hole in the handbrake bracket with a #72 drill and fit the handbrake spiders, glue in place.
6. Carefully wash the complete kit with warm soapy water and paint gunmetal grey all over. The board floor and the tops of the metal floor plates may be painted a flat medium to dark grey with streaks of black to simulate distressed timber. Ensure the areas where the decals are to be applied have a gloss finish. Add decals and paint all over with a flat clear finish to seal the model.
8. Fit Kadee #5 couplers and adjust height by packing between the bogies and the floor if required.
9. **Important Note:** If you damage any part during the construction of this model please contact us by writing to the above address or through the email address. A replacement part is available free of charge.
10. Fit the bogies with the pins supplied. Alternatively the pins supplied can be glued into the bogie pin hole and later cut off level with the top of the bogie bolster. When the join has cured centre mark and drill with a 1.8mm drill. Attach the bogies with a screw.
11. Using the enclosed diagram as a guide set your two tractor models in position and center them on the floor so that they are equidistant from each side.

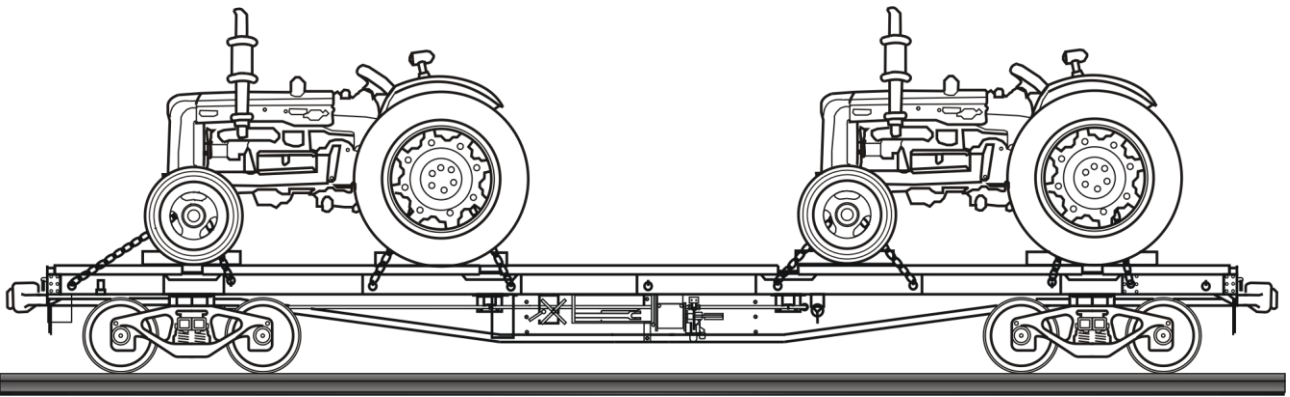

12. You will note that they have been positioned so that the front wheels of one tractor and the rear wheels of the other tractor have been positioned over the center of the bogie bolsters.
13. Identify the tie down loops at the positions where the chains are attached to the side sill of the wagon. Drill a #71 drill hole through the center of the tie down loop.
14. Take a length of copper wire and form it into a U shape, Make sixteen of these as they are used to attach the chain to the side sill. Hold your tractors in position by either gluing them in position with a spot of super glue or put a small pad of blue tack under the tires.
15. Paint the wheel chocks either grey and with a very thin wash of black to simulate older wood or paint it a orange brown and apply a thin wash of black to simulate new wood. Glue them in position so that the angled end is under the tires.
16. Start lashing the tractors down by passing a u shape of copper wire through the end loop of the chain. Push the two open ends of the wire through the #71 drill hole and splay the ends on the inside of the side sill and cement in position with a small amount of super glue. Loop the chain over the axel of the front wheel of the first tractor. By process of elimination pass the second loop of copper wire through loops in the chain and push them through the second #71 drill hole in the side sill until the chain is taught. When you have achieved this repeat the process for the remaining axels until you have the tractors secured each side. This should give you an authentic model of a flat wagon being used for the transport of farm machinery from the major distribution centre to the bush.
18. Fit the bogies with the pins supplied. Alternatively the pins supplied can be glued into the bogie pin hole and later cut off level with the top of the bogie bolster. When the join has cured centre mark and drill with a 1.8mm drill. Attach the bogies with a screw.
19. A further article on attaching chains to flat wagons can be found at the resources page of our website at

<http://www.arkits.com/page/Articles>.